



# Alnico

## Alnico – Pots

Alnico Pots, offers a better holding force than Ferrite systems in a comparable size and is the only pot magnet that can be heated to extreme temperatures. However, the high cost of the Cobalt content in the cast magnet makes the price prohibitive unless the application requires temperatures over +120°C up to a maximum of 500°C.

Style A pots, Shallow pot with a countersunk hole on the active face and can be easily fixed using a countersunk screw.

Style B is a deep pot that has an internal thread on the non-active face.

Alnico High Temp Shallow Pot (up to 500 °C)						
Dimensions (mm)						
Part Number	Style	ØD	Ød1	H	Tapered Screw	Holding Force (kg)
ALSP 00217	A	19.1	4.2	7.6	M4	3.0
ALSP 00218	A	28.6	5.2	8.7	M5	5.0
ALSP 00219	A	38.1	5	10.6	M5	13.0
Supplied Magnitised and Kepered						

Alnico High Temp Deep Pot (up to 500 °C)					
Dimensions (mm)					
Part Number	Style	ØD	H	Ød1	Holding Force (kg)
ALDP 00547	B	17	16	M6	2.5
ALDP 00983	B	27	25.5	M6	6.1

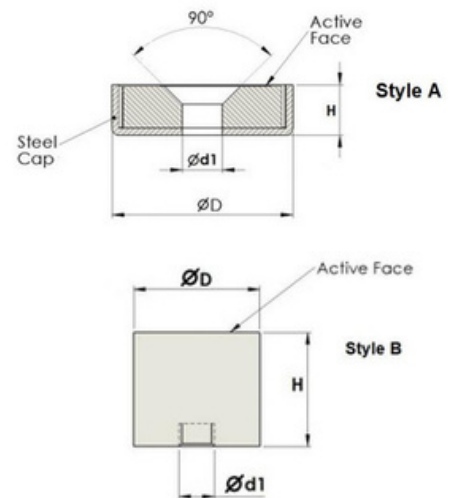

Please note:  
 Holding Forces are based upon direct contact with a thick, clean mild steel surface. Holding Forces will be reduced with heavily painted or corroded surfaces.  
 Over tightening screws can lead to cracking and other damage. Therefore these pots should not be used for mechanical holding applications.  
 Please take care when selecting a screw to use in conjunction with these pots as a steel screw could alter the flux and reduce the magnetic force.  
 We suggest using 304 stainless steel screws where possible.  
 Before selecting a choice of holding system please consider the working environment of your application.